



# WSB40

## 10" Medium-Duty Quik Stik Plus® Immersion Blender



10" Medium-Duty Quik Stik Plus® Immersion Blender



### MAIN FEATURES

- ½ HP, 2-speed, heavy-duty motor
- 10" fixed shaft
- Rubberized comfort grip
- All-purpose, stainless steel blade
- 6-gallon, 24-quart capacity
- Limited One Year Warranty

### ELECTRICAL

Voltage: 120

Frequency: 60Hz

Watts: 350

Amps: 2.9

Plug Type: NEMA 5.15P ⓘ

Cord Length: 10 feet



### SALES FEATURES

Easily purée, whip and emulsify anything with the 10" Waring® WSB40 Quik Stik Plus®. This medium-duty immersion blender has high and low speeds, along with a rubberized comfort grip for safe and controlled operation. Its all-purpose, stainless steel blade and shaft are easy to clean and lightweight, while its ½ HP heavy-duty motor revs up to 18,000 RPM.



@waringcommercial

©2019 Waring Commercial  
314 Ella T. Grasso Avenue, Torrington, CT 06790  
Tel. 800-492-7464 • Fax 860-496-9008

[waringcommercialproducts.com](http://waringcommercialproducts.com)

WSB40



# 10" Medium-Duty Quik Stik Plus® Immersion Blender WSB40

## PARTS & ACCESSORIES



**WSB01** Wall Hanger for Immersion Blenders

## DIMENSIONS

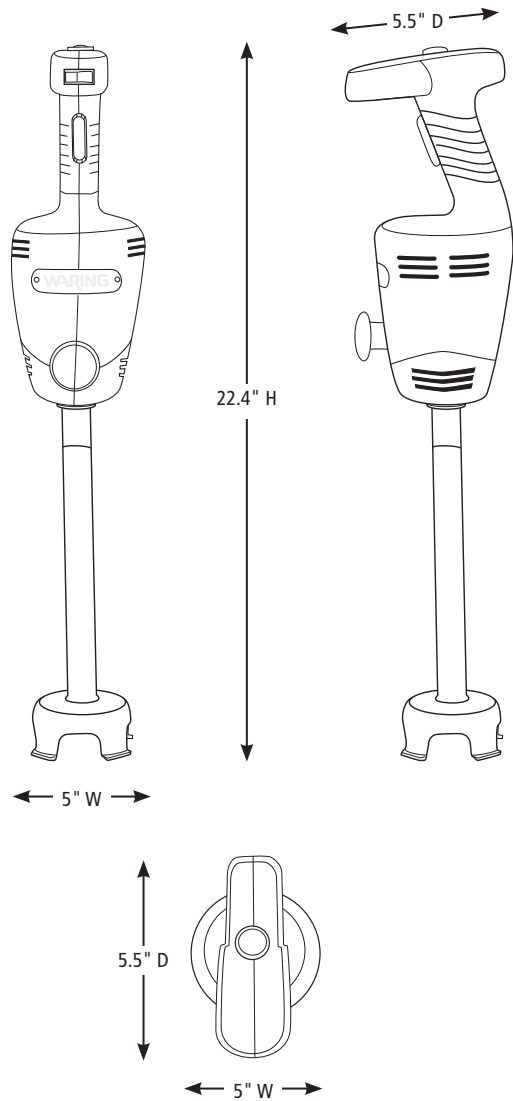

Out of Box Weight: 5.2 lb.

ORDERING INFORMATION	#STD. PKG.	GIFTBOX WEIGHT	CUBIC FEET	BOX DIMENSIONS D X W X H	UPC	CASE PKG.	MC WEIGHT	MC DIMENSIONS D X W X H	MBC
WSB40 – Quik Stik Plus® Immersion Blender	1	6.3 lb.	.400	5.375" x 5.750" x 22.375"	040072002830	2	12.6	6.125" x 12.125" x 22.875"	10040072002837



@waringcommercial

©2019 Waring Commercial  
314 Ella T. Grasso Avenue, Torrington, CT 06790  
Tel. 800-492-7464 • Fax 860-496-9008

waringcommercialproducts.com

19WC059588 / REV 07/19