



CB15P

1 Gallon, 3-Speed Food Blender



1 Gallon, 3-Speed Food Blender



MAIN FEATURES

- Ultra heavy-duty, 3.75 HP commercial motor
- 3 speed selections and MAX PULSE to chop and mix
- Easy-to-clean and easy-to-use electronic membrane keypad
- Durable, high-performance stainless steel blade
- The stackable, 1 gallon, BPA-free copolyester container makes storage easy
- Easy-off, rubberized lid with removable clear cap for adding ingredients and for pressure reduction during hot food blending
- Metal-on-metal, stainless steel coupling system for durability and reliability
- Durable, full die-cast motor housing with rugged rubber feet to reduce vibration
- Dishwasher-safe, one-piece jar pad for easy cleaning
- Recommended for 100+ drinks or servings per day
- Limited Three-Year Motor Warranty

*Made in USA with US and foreign parts.

ELECTRICAL

Voltage: 120

Frequency: 60Hz

Watts: 1800

Amps: 15

Plug Type: NEMA 5-15P

Cord Length: 3 feet



SALES FEATURES

The Waring® CB15P has your back when it comes to ultra heavy-duty blenders, making 100+ drinks per day. Chop, mix and shred large loads that need long blending times with a powerful 3.75 HP motor and electronic keypad controls. The stackable, 1 gallon, BPA-free copolyester container makes storage easy.



@waringcommercial





©2019 Waring Commercial
314 Ella T. Grasso Avenue, Torrington, CT 06790
Tel. 800-492-7464 • Fax 860-496-9008

waringcommercialproducts.com

CB15P



INCLUDED ACCESSORIES

-  **CB15BU** Base Unit
-  **CAC77** Vinyl Lid for 1-Gallon Blender Jar
-  **CBL10** Hot Blending Lid for 1-Gallon Blenders
-  **CAC170** 1-Gallon, Stackable, 128 oz., BPA-Free Copolyester Container with Blade Assembly and Lid

OPTIONAL ACCESSORIES

-  **CAC125** Two-Handle, 1-Gallon Stainless Steel Container with Spigot, Blade Assembly and Lid
-  **CAC32** 40 oz. Glass Container Complete with Blade Assembly and Lid (requires AD1)
-  **AD1** 1-Quart Adapter for 1-Gallon Blenders
-  **CAC19** 48 oz., BPA-Free Copolyester Container Complete with Blade Assembly and Lid (requires AD1)
-  **CAC33** 32 oz. Stainless Steel Container Complete with Blade Assembly and Lid (requires AD1)
-  **CAC02** Outer Lid ONLY for 48 oz., BPA-Free Copolyester or 64 oz. Stainless Steel Container
-  **CAC04** Outer Lid ONLY for 32 oz. Stainless Steel Container
-  **CAC05** Center Lid ONLY for CAC01, CAC02, and CAC04

DIMENSIONS

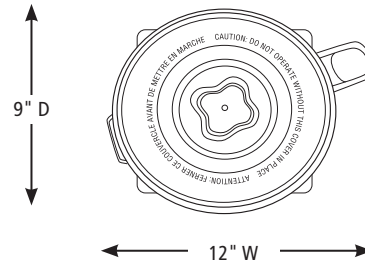
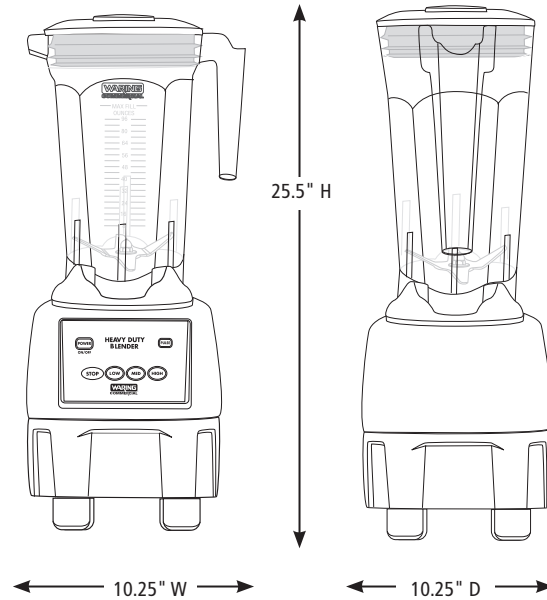

Out of Box Weight: 28.9 lb.

ORDERING INFORMATION	#STD. PKG.	GIFTBOX WEIGHT	CUBIC FEET	BOX DIMENSIONS D X W X H	UPC	CASE PKG.	MC WEIGHT	MC DIMENSIONS D X W X H	MBC
CB15P – 1 Gallon, 3-Speed Food Blender	1	35.0	2.722	14.375" x 14.875" x 22"	040072088247	1	35	15.3" x 16" x 22.5"	10040072088244



@waringcommercial

©2019 Waring Commercial
314 Ella T. Grasso Avenue, Torrington, CT 06790
Tel. 800-492-7464 • Fax 860-496-9008

waringcommercialproducts.com

19WC064509 / REV 08/19